

Identify. Quantify. Simplify. See the Whole Picture.

Agilent 7250 GC/Q-TOF system



Ready to Achieve More?

Discovering what's in your sample, at what levels, helps you make the conclusions and breakthroughs that your organization depends on.

The all-in-one Agilent 7250 GC/Q-TOF system, together with comprehensive Agilent MassHunter software, provides you with timely, confident answers across your most challenging GC/MS applications. It's the premier instrument for your toughest GC/MS identification, quantification, and exploration challenges:

- Performing complex metabolomics studies
- Screening for pesticides in challenging matrices
- Identifying compounds in diverse matrices
- Testing contaminant levels in chemical feedstock

Designed for real-world performance and built for laboratory robustness, the 7250 GC/Q-TOF system delivers what your organization needs: consistently excellent results.



Ultimate confidence for routine screening workflows and once-in-a-lifetime discoveries

The 7250 GC/Q-TOF gives you more:

- Sensitive detection
- Accurate quantification
- Power to explore
- Simplified spectra
- Reproducible data
- Dynamic range

So you can worry less about:

- Future regulation
- Uncertain results
- True unknowns
- Data interpretation time
- Replicate ambiguity
- False negatives and false positives

Evolving analytical challenges call for new methods and novel approaches

For over 40 years, Agilent innovations have helped diverse labs meet the demand for ever-more-detailed analysis. The 7250 is our most advanced GC/Q-TOF, and it's designed to provide outstanding performance and laboratory robustness.

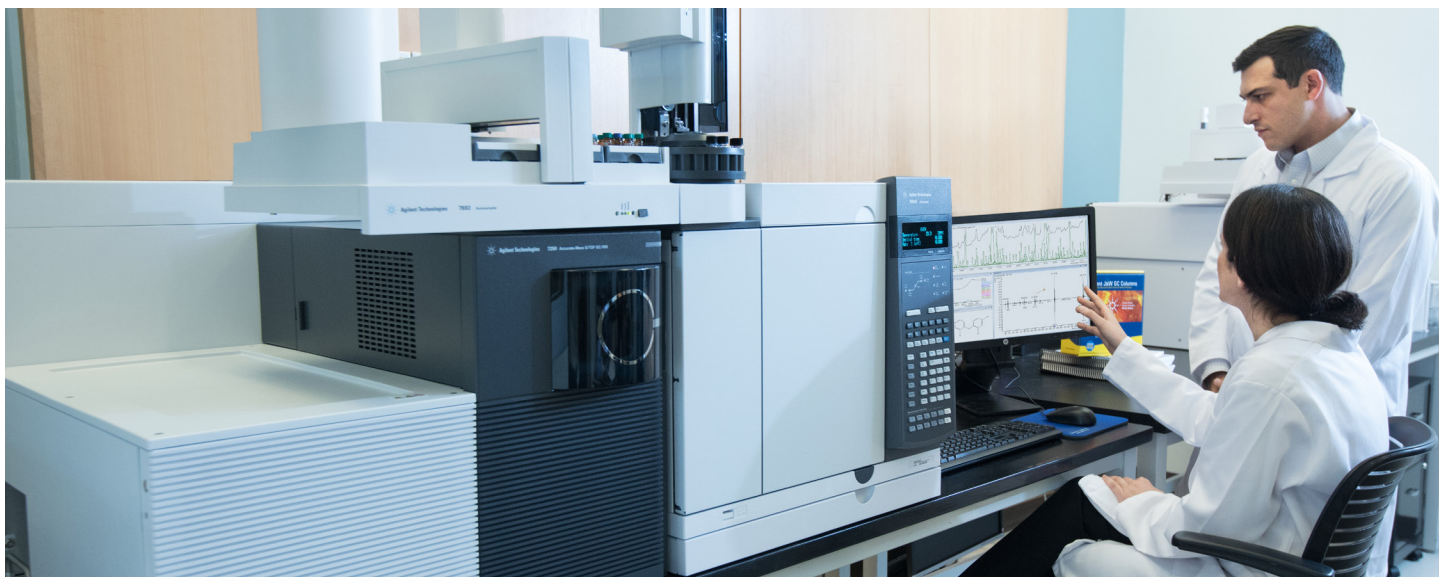

Need More Confident Identification?

“The Agilent instruments are very useful in our laboratory for three reasons: they’re reliable, accurate, and easy to use.”

– **Mike Thurman, PhD**

Center for Environmental Mass Spectrometry, University of Colorado

Not seeing the whole picture can have serious implications for your research, development, and quality control. The analytical prowess of the Agilent 7250 GC/Q-TOF system and MassHunter software brings you unmatched compound identification abilities.

- **Know your compounds.** Undistorted library-quality spectra let you confidently identify compounds against commercial libraries.
- **Confirm formulas.** Isotopic fidelity gives you greater certainty when assigning molecular formulas.
- **Detect trace analytes.** Ensure a broad in-spectrum dynamic range, even with abundant coelution.
- **Elucidate structures.** MS/MS measurements with high-resolution, accurate mass product ion spectra can provide structural information, increase selectivity, and circumvent matrix interferences.

Confidence in library hits due to spectral fidelity and accurate mass

You can easily identify compounds by doing a spectral search against commercially available libraries. The 7250 GC/Q-TOF system supports the quality of hundreds of thousands of compound library spectra, most of which were generated by Agilent quadrupole GC/MS systems. True-to-library EI fragmentation patterns, together with accurate mass information, make the 7250 GC/Q-TOF system an ideal platform for compound identification using EI libraries.

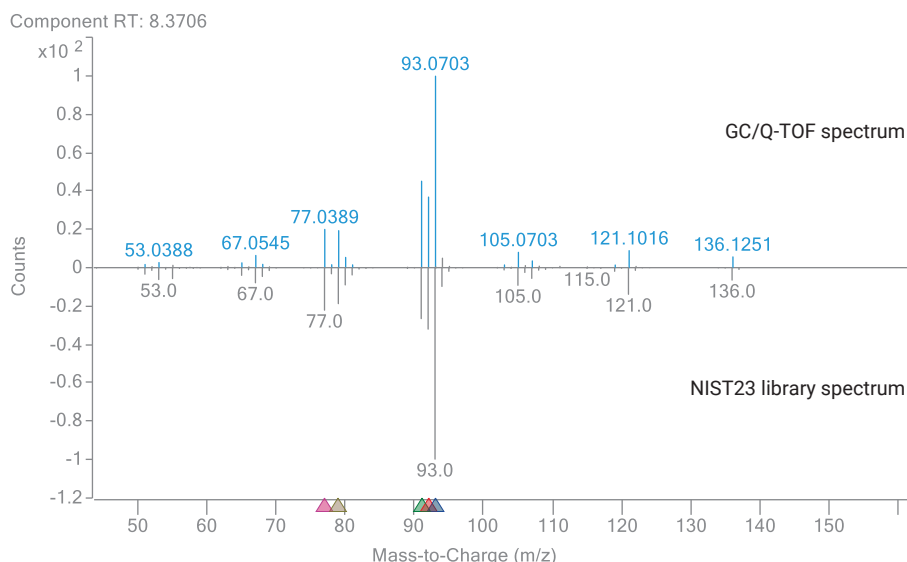

α -Pinene in soil. Library Match Score: 95.8

Components							
Component RT	Compound Name	Match Factor	Best Hit	Formula	Component RI	Library RI	Delta RI
8.3706	(1R)-2,6,6-Trimethylbicyclo[3.1....	95.8	<input checked="" type="checkbox"/>	C10H16	932	932	0

Isotopic fidelity

Confident compound identification demands more than good mass accuracy. It also requires you to consider independent compound characteristics like isotopic pattern matching.

You can easily picture isotopic fidelity through MassHunter Qualitative Analysis. It allows you to identify compounds based on characteristics complementary to accurate mass measurement. The Agilent 7250 GC/Q-TOF system exhibits excellent isotopic fidelity, even for trace-level isotopes, as shown in this dodecane spectrum with a low-abundance M+ peak cluster.

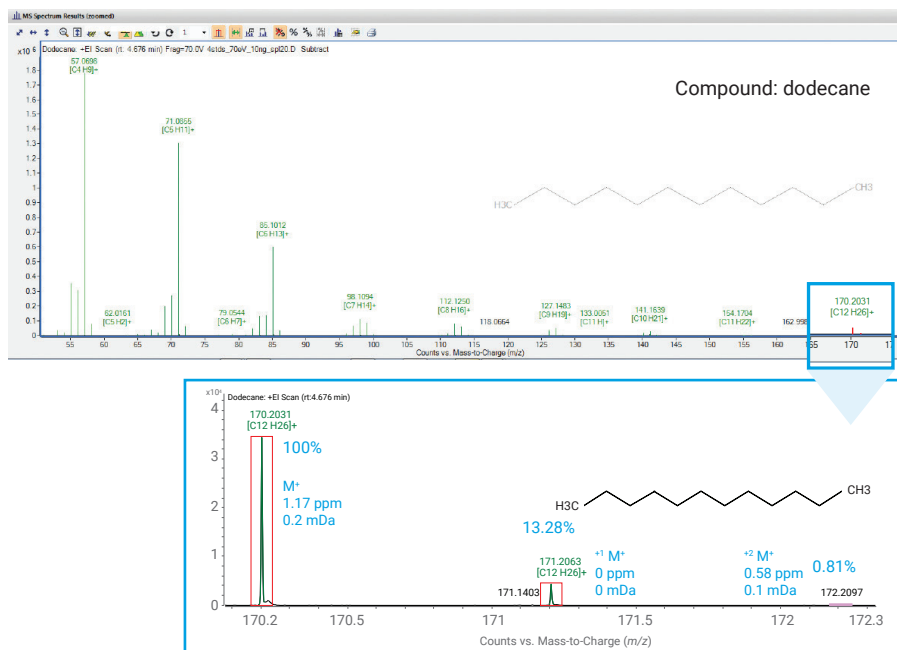

High resolution and mass accuracy for pesticides

To separate analytes from interferences, high resolution is necessary. However, when analyzing complex matrices for trace-level components, other performance characteristics—such as wide dynamic range and high sensitivity—must also be maintained.

The example shown here represents such a scenario: analyzing the insecticide thiamethoxam at 5 ppb in avocado, a complex matrix with significant background. Even under these conditions, characteristic mass peaks are separated from background with mass accuracy that complies with EU SANTE/11945/2015 guidelines.

What's more, this level of spectral performance is achieved regardless of acquisition speed or mass range.

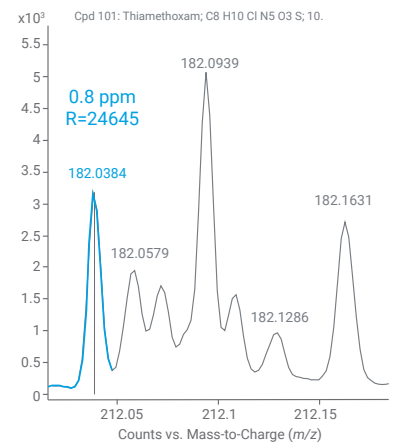
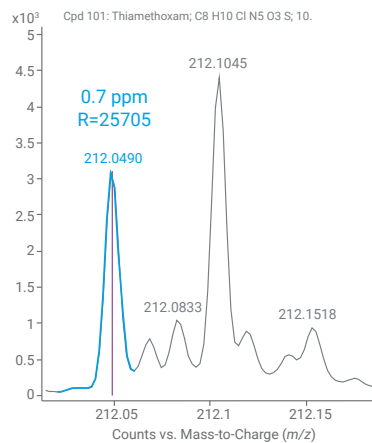

Wide dynamic range in complex matrix

A wide in-spectrum dynamic range lets you confidently detect trace-level analytes in the presence of abundant background or other coelutents. The 7250 typically provides four orders of in-spectrum dynamic range, even in heavy matrices. This example displays a range of 16,000+:1 for phosphorylethanolamine (4TMS) in a complex biological sample of mouse lung extract.

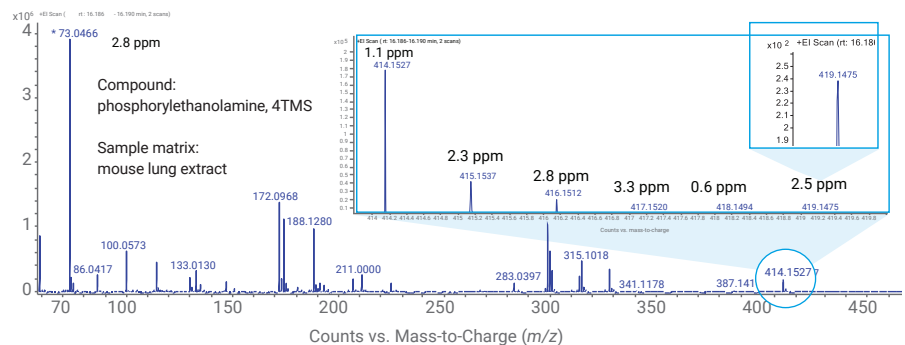

Agilent Value Promise

We guarantee you at least 10 years of instrument use from the date you buy. Otherwise, we will credit you with the residual value of the system toward an upgraded model.

Elucidate chemical structures and reveal greater detail

The 7250 GC/Q-TOF is the only accurate mass time-of-flight system with MS/MS capabilities. Using MS/MS product ion spectra generated from a putative molecular ion, Molecular Structure Correlator software can propose compound structure possibilities and likelihoods based on fragment data.

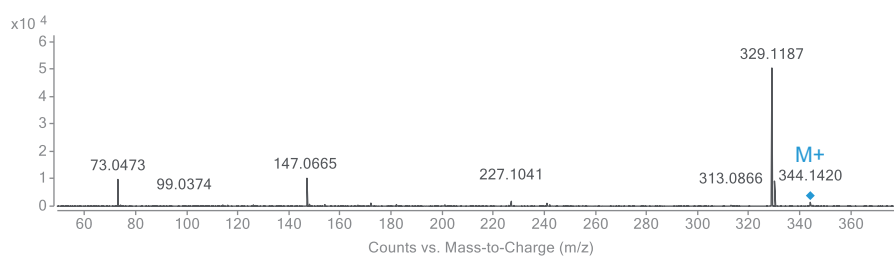

48 structures found for rt=14.408:ce20

Sort by: # Reference | Show structures for: C13H28N2O3Si3

Structure #	Mass	Intensity	Weight(%)	No. of candid.	Best score
1	329.1187	50455.72	78.7	2	90.7
2	147.0665	10204.34	3.2	4	42.2
3	73.0473	9762.28	0.7	1	98.6
4	330.1197	9215.45	14.5	2	55.4
5	227.1041	1790.00	1.3	0	0.0
6	172.0981	1129.09	0.5	0	0.0
7	241.0467	1073.97	0.9	2	95.0
8	148.0672	707.77	0.2	1	66.9

Structure #1 -- elucidated: 75.0% ions, 98.2% Weight

Penalty=1.0 dM=-5.3ppm F.D.S.=91.0 C12H26N2O3Si3-H Score=90.7 | Penalty=9.5 dM=-5.9ppm F.D.S.=91.0 C12H30N2O3Si3-5H Score=65.1

Chemical structures of candidates for Structure #1, showing a pyridine ring substituted with three trimethylsilyloxy groups.

Compounds with unknown identities or structures can be interrogated to narrow the range of possibilities.



Searching for Better Quantitative and Qualitative Answers?

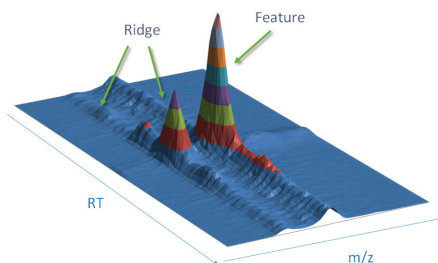

The Agilent MassHunter SureMass algorithm for detecting chemical features is designed specifically for high-resolution MS profile data.

Targeted quantification with untargeted acquisition is a powerful combination. The Agilent 7250 GC/Q-TOF system delivers unmatched quantitative accuracy with its simultaneous high mass resolution and wide dynamic range. What's more, state-of-the-art electronics enable broad linearity and consistent responses even for trace analytes in complex matrices.

SureMass, a unique signal-processing algorithm optimized for high-resolution accurate mass data, further increases linear dynamic range. It also helps achieve superior mass accuracy while providing high speed and sensitivity of chromatographic deconvolution for nontargeted analysis.

Accurate quantification in a complex matrix

A wide linear dynamic range brings quantitative accuracy across varying concentrations. Response factors are maintained even at low concentrations in complex samples, as shown in this calibration curve for fonofos from 0.5 to 1,000 ppb in avocado matrix.

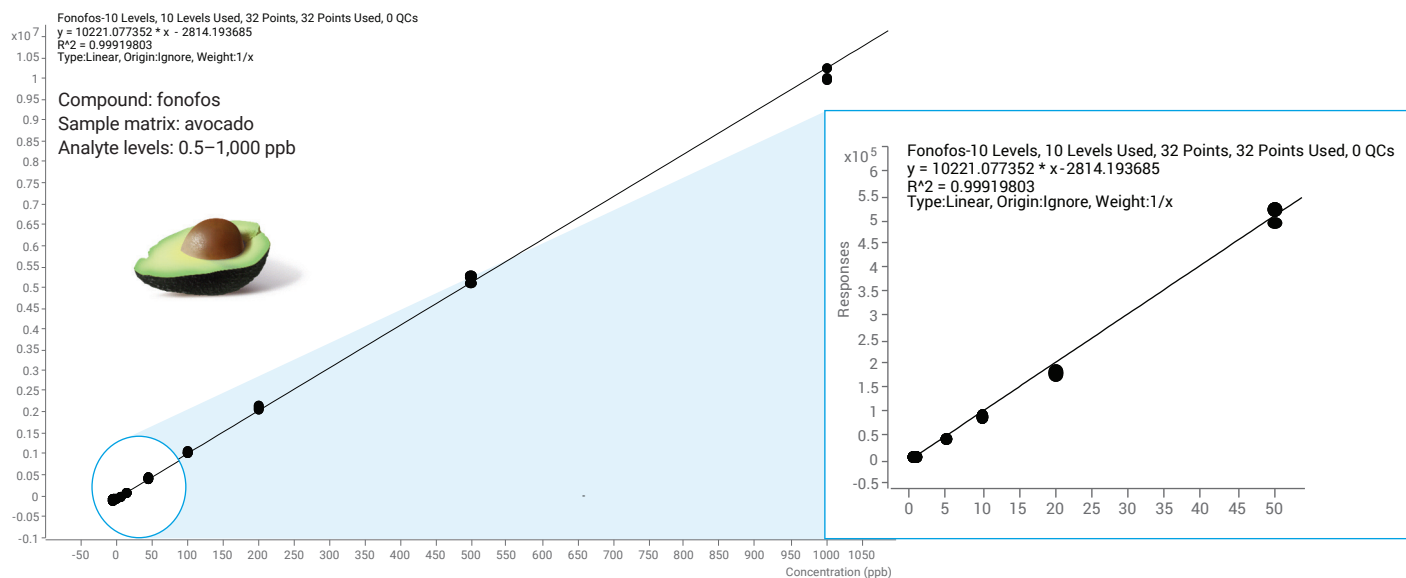

Facilitate Compound Identification with Alternative Soft Ionization Techniques

Enable previously impractical—or impossible—workflows with the 7250, the world's only high-resolution GC/Q-TOF. It lets you create simplified spectra without relying on specialty techniques, while retaining the universal applicability of electron ionization (EI).

The 7250 low-energy-capable EI source is based on the proven high-efficiency source (HES) in Agilent 5977 GC/MSD and 7010 GC/TQ systems. It has been optimized for low-energy EI operation, yet still performs at conventional 70 eV ionization. In addition, HES design modifications amplify the analytical sensitivity of low-energy EI for a paradigm shift in GC/MS soft ionization.

Combined with interchangeable chemical ionization sources that enable both PCI and NCI, the soft ionization options for the 7250 GC/Q-TOF system simplify your most challenging analyses.

- **Identify with confidence.** Gain information about molecular ions for downstream structural elucidation.
- **Stretch your limits.** Ionize across analyte classes while avoiding major analytical sensitivity losses common with other soft ionization techniques.
- **Improve efficiency.** Harness the proven performance of ion source technology from the global GC/MS leader.

The 7250 low-energy EI source

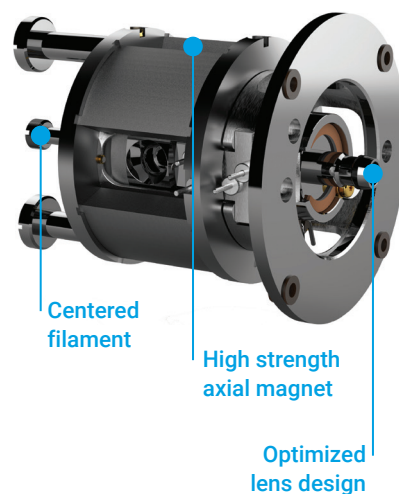

Overcoming the challenges of identifying metabolites in complex matrices

Lowering the source ionization energy creates a spectral tilt toward the molecular ion. Here, lower electron energy corresponds to a higher relative abundance for the molecular ion of this unknown compound.

Identification of the molecular ion using low-electron energy

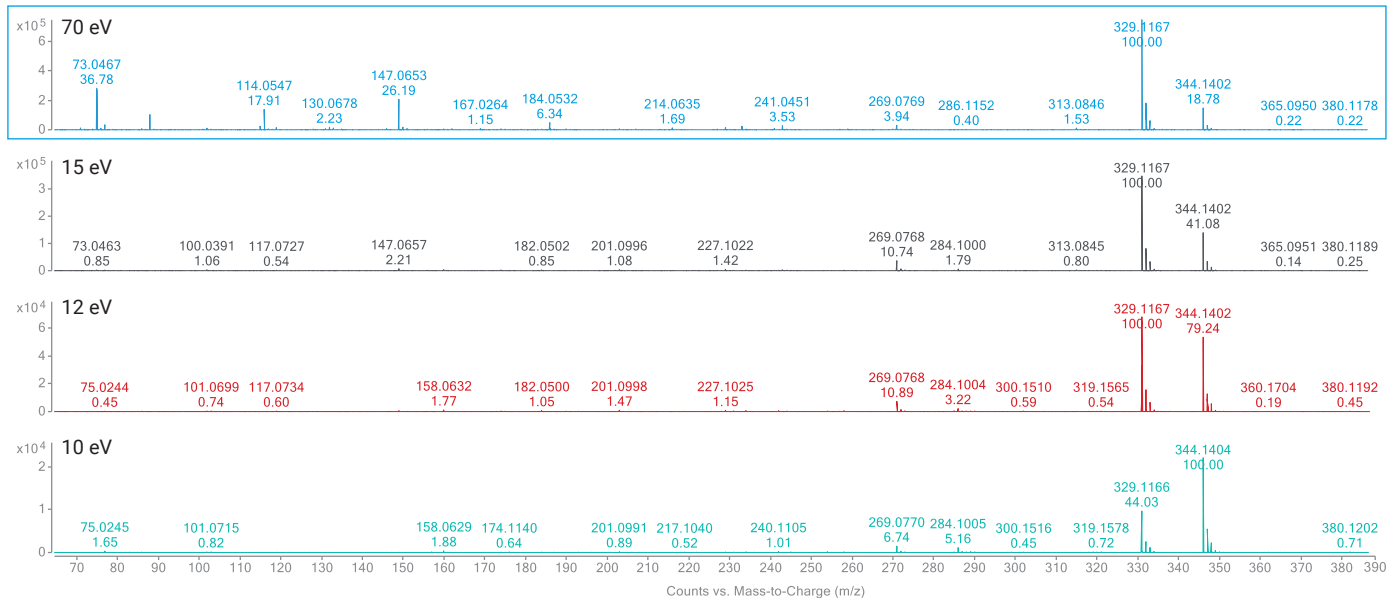

Protect Customers and Your Reputation by Solving Real-World Challenges

Food producers and consumers face threats from adulteration and fraudulent labeling. In addition, global trade, stringent regulations, and increased public awareness are driving the need for more frequent and detailed food testing.

The 7250 GC/Q-TOF system helps you meet these challenges with a single optimized platform. Typical GC/Q-TOF uses in food testing include:

- Suspect screening with target quantitation based on the accurate mass pesticide PCDL
- Nontarget screening using SureMass deconvolution and extensive unit mass EI libraries such as NIST
- Food classification for fraud detection



Matrix matters

Untargeted acquisition and accurate mass spectral libraries let you comprehensively screen for pesticides in food matrices.

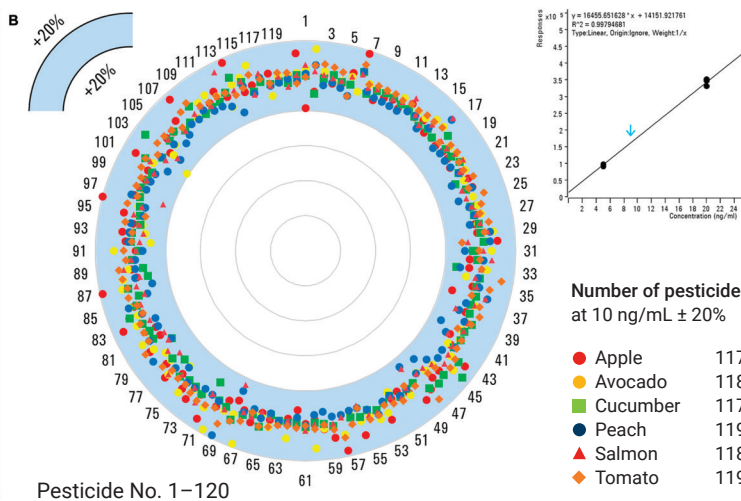
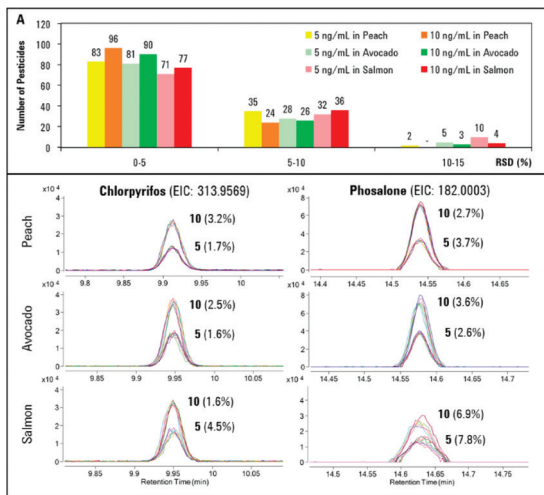

120 pesticides spiked into three different food matrices, including avocado and salmon. The repeatability (RSD %) values for spiking levels of 5 and 10 ng/mL confirm excellent analytical performance. Two examples of detected characteristic ion replicates are also shown.

Quantitative accuracy at 10 ng/mL. A rapid comparison against maximum residue limits (MRLs) is shown for six food matrices of varying complexity. Even for complex matrices like avocado and salmon, quantitative accuracy complies with EU SANTE/11813/2017 guidelines for over 97% of the pesticide/food pairs tested.

Easy recognition of false positives using the GC/Q-TOF suspect screening workflow

Easily evaluate large sample batches for hundreds of target and suspect compounds with a single analysis method. MassHunter software provides simultaneous quantitative measurement for target compounds. It also lets you screen against high-resolution spectral libraries for suspect compounds with no calibration reference.

Perform simultaneous target and suspect screening using one data analysis tool

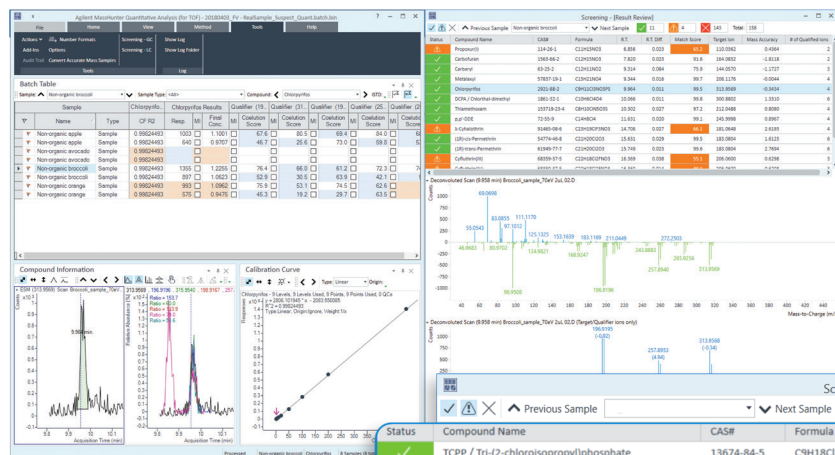

An Agilent 7250 GC/Q-TOF system, combined with our GC/Q-TOF Personal Compound Database and Library (PCDL) of pesticides and environmental pollutants, lets you qualitatively screen for over 1,000 compounds of interest. All without the need for authentic standards. To expand your screening scope, a simplified workflow lets you customize any PCDL.

"The GC/MS Q-TOF system enabled us to confirm the positive, but also to avoid false positive results."

– Peter Furst, PhD

Department of Central Analytical Services, Chemical and Veterinary Analytical Institute, Münsterland-Emscher-Lippe

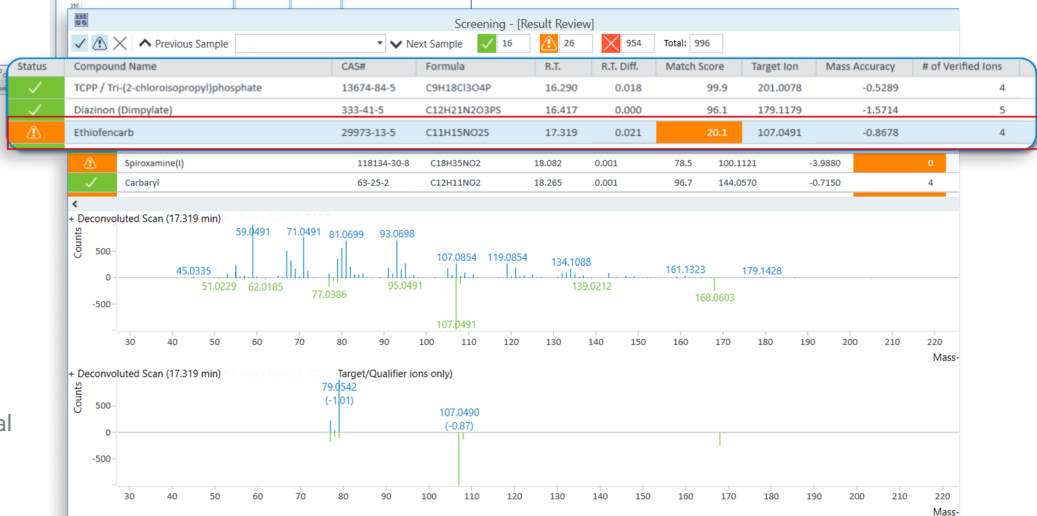

The power to differentiate true hits from false identifications, even when there's no standard run to compare to, reflects the 7250 GC/Q-TOF system's high resolution and accurate mass performance.

Confirming food authenticity and detecting fraud

Food fraud is a rapidly growing and evolving business. Time-of-flight (TOF), combined with a nontargeted approach, is a fast-rising method for detecting food fraud and adulteration. To streamline the characterization of foods with high-resolution GC/Q-TOF, use Agilent Mass Profiler Professional (MPP) software to create a classification model and Agilent MassHunter Classifier software to detect fraud.

MassHunter Classifier software visualization tools include compound lists and three-dimensional PCA plots

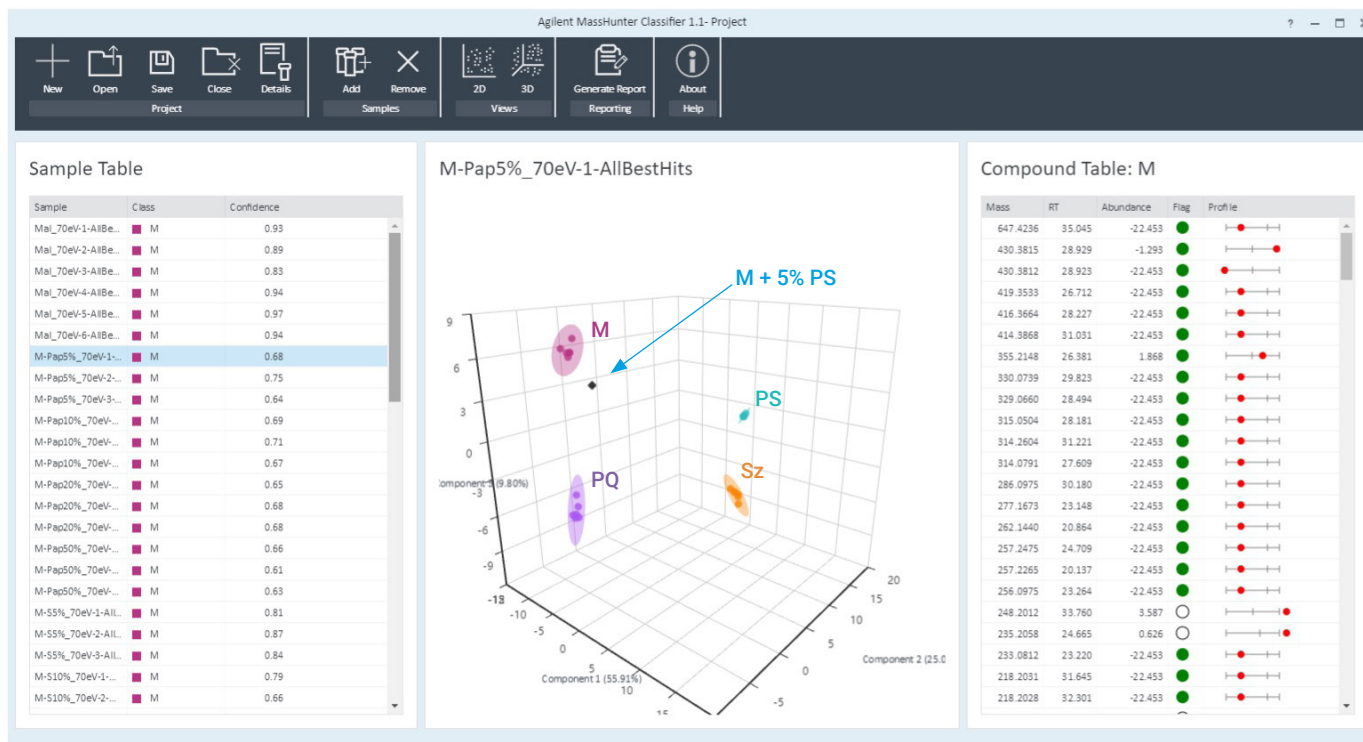

High-resolution accurate mass GC/Q-TOF data, as well as differential analysis software, enables routine food sample screening for classification and food fraud detection.

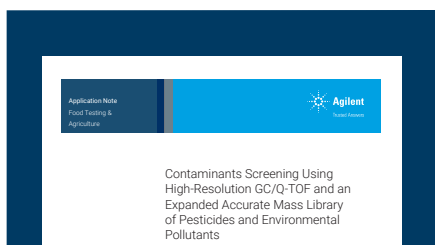

Want to see how Q-TOF protects against false positives?

Read about a streamlined workflow for screening and quantitating pesticides and environmental contaminants in strawberry extracts using high-resolution GC/Q-TOF and an accurate mass library. [Download application note](#)

Screen for Known Contaminants and Identify Unknowns

Every day, new questions arise about the impact of humanity on the environment—and about the environment’s impact on us. The revolutionary technological enhancements in the Agilent 7250 GC/Q-TOF system are designed to provide meaningful answers with ease and efficiency.

The use of accurate mass high-resolution MS (HRMS) techniques to characterize known and unknown pollutants is gaining in popularity. To achieve high sensitivity, together with an expanded analysis scope, the 7250 can be used in comprehensive workflows that include:

- Targeted quantitation
- Suspect screening
- Nontargeted screening for contaminants

In addition, retrospective processing lets you measure once and process data repeatedly with full-spectrum data that you can interrogate for future emerging targets.



Be sure in your identification

MassHunter Unknowns Analysis software, using SureMass signal processing and ExactMass tool, gives you efficiency and sensitivity beyond conventional deconvolution techniques. Even minor components are accurately extracted and identified in the presence of a dominating background signal.

The ExactMass feature annotates ions with fragment formulas, letting you confidently identify compounds even when using MS libraries with nominal mass spectra from quadrupole MS systems.

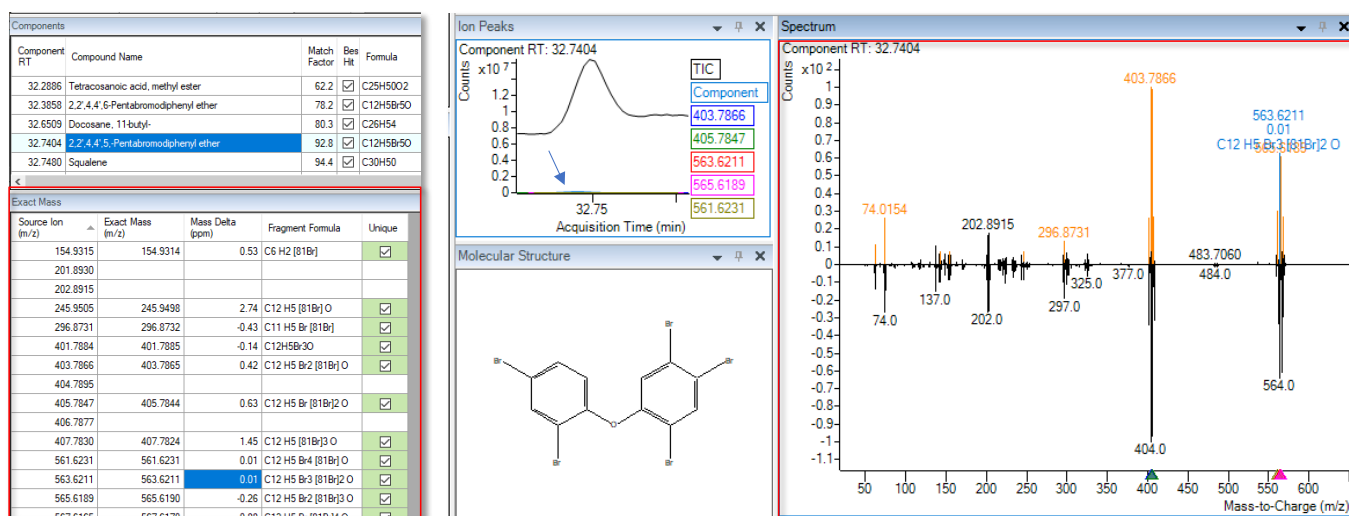

The ExactMass tool (red rectangles) helps provide additional confirmation of unit mass library hits based on accurate mass. Representative compound ions are highlighted in the mirror plot when m/z corresponds to the library hit formula. The blue arrow points to the deconvoluted component in soil matrix.

Accurate mass library for PFAS analysis in environmental samples

Developing accurate mass libraries in environmental applications is key to expanding the scope of monitored compounds and enabling confident target/suspect detection. It also provides the opportunity to use a suspect screening approach that offers higher sensitivity and flexibility compared to nontarget screening.

Examples of different PFAS compound classes from the PFAS PCDL

Nonfluoro-1-iodobutane (PFBI)

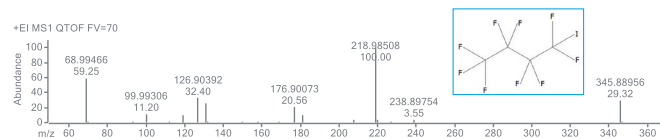

8:2 Fluorotelomer acrylate (8:2 FTAC)

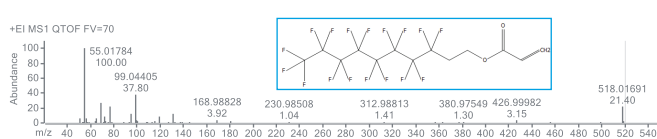

1,1,1,2,2,3,3,4,4-Nonafluoro-6-iodohexane (6:2 FTI)

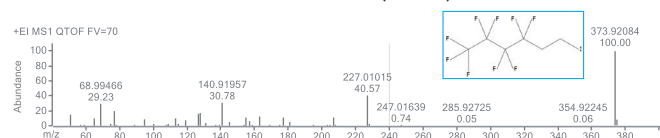

2,2,3,3,4,4,4-Heptafluorobutyl methacrylate (3:1 FTMAC)

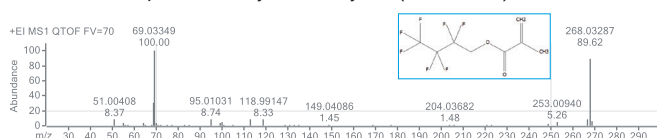

6:2 Fluorotelomer alcohol (6:2 FTOH)

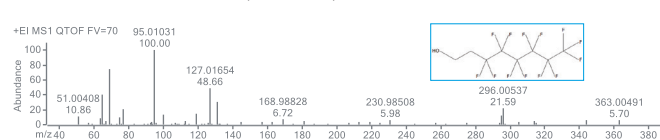

Perfluoroheptanoic acid (PFHpA)

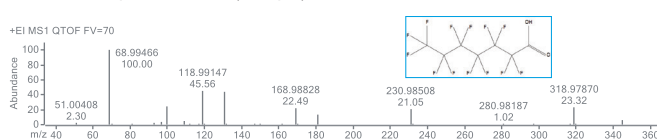

Fluorotelomer alcohol detected in soil using the GC/Q-TOF screener and PFAS PCDL

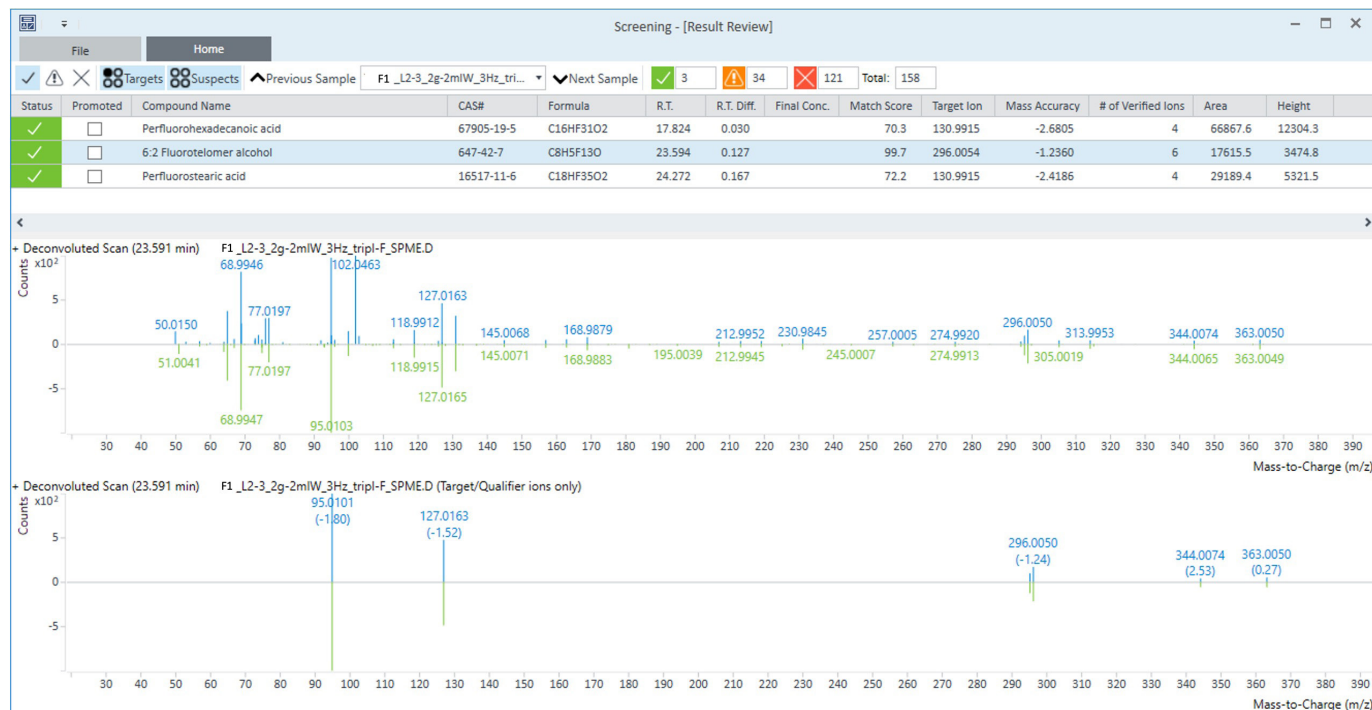

Power Your Productivity and Ensure Product Quality

Characterizing what's in a complex sample is no simple task. It takes knowledge, insight, and the powerful analytical capabilities found in the Agilent 7250 GC/Q-TOF system. These capabilities include high-resolution accurate mass measurements, low-energy electron and chemical ionization options, fast spectral acquisition for comprehensive GC x GC compatibility, and highly sensitive MS/MS measurements.

- Fast acquisition rates of up to 50 Hz and speed-independent resolving power let you characterize narrow chromatographic peaks or ultranarrow 2D GC peaks.
- Spectral simplification allows you to deduce molecular ions, so you can take advantage of soft GC/MS ionization options.
- High-resolution accurate mass product ion spectra, combined with powerful Molecular Structure Correlator software, yield insights on chemical structures.



Paraffins and naphthenes

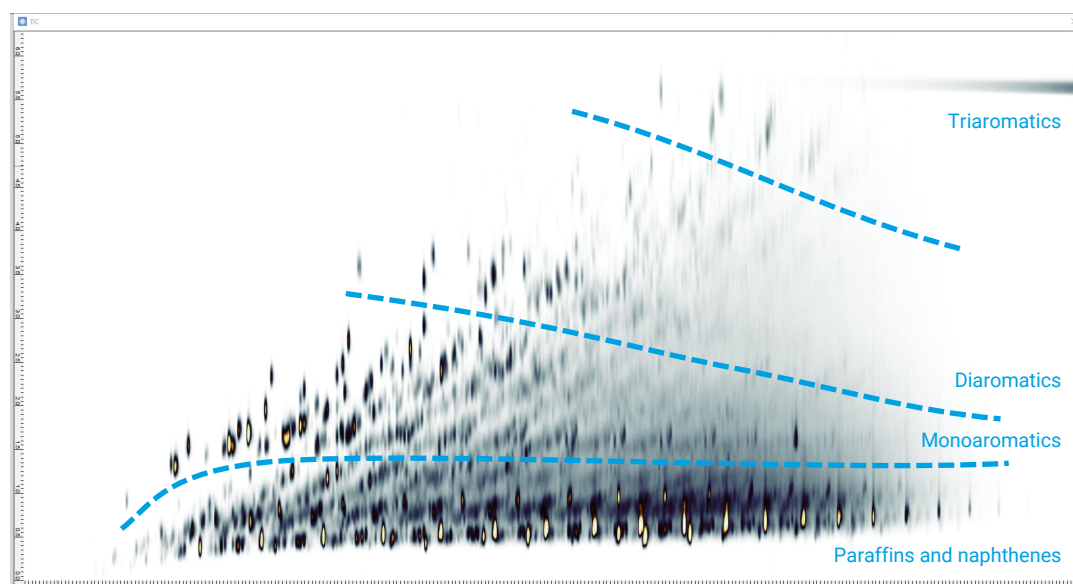

This figure depicts how the Agilent reverse-flow modulator helps achieve reliable results. The comprehensive 2D GC graph illustrates the accurate separation of diesel constituents.

Hexadecyl sulfide: C₃₂H₆₆S

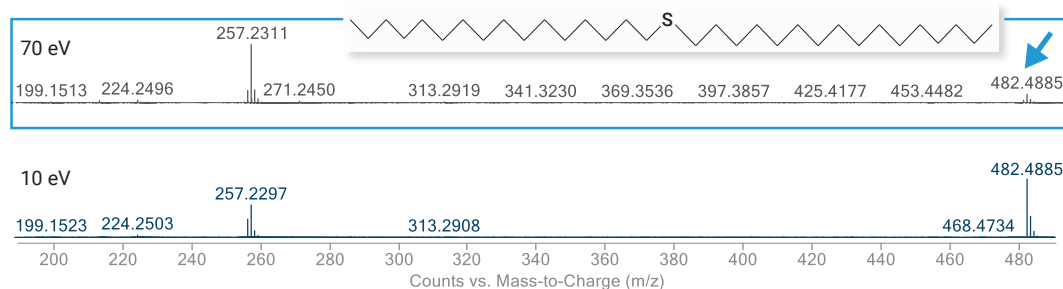

Reduce spectral complexity with revolutionary low-energy electron ionization source that greatly maintains analytical sensitivity while enabling a spectral tilt toward molecular ions.

Advance Your Study of Systems Biology

Each day brings new insights into human health, diagnostics, and disease understanding. The research that drives these advances requires painstaking experimental design and execution. Move your research forward with high-resolution data produced by the Agilent 7250 GC/Q-TOF system and software. Together, they enable you to identify more compounds in biological matrices and reveal hidden trends.



A pathway-centric metabolomics workflow

Complex metabolomic studies benefit from the full-spectrum analytical sensitivity and mass accuracy of the Agilent 7250 GC/Q-TOF system, as well as its MS/MS ability to structurally elucidate unknown metabolites. The system's extended dynamic range allows accurate, simultaneous quantification of metabolites present in a cell.

Pathway Architect, available with Mass Profiler Professional, brings a biological context to mass spectral data. With Pathway Architect, you can take results from single or multiple "omics" experiments and map them onto canonical biological pathways. You can also concurrently analyze, picture, and interpret pathway information. This pathway-centric workflow speeds your route from discovery and insight to validation—and enables you to efficiently plan and execute your next series of experiments.

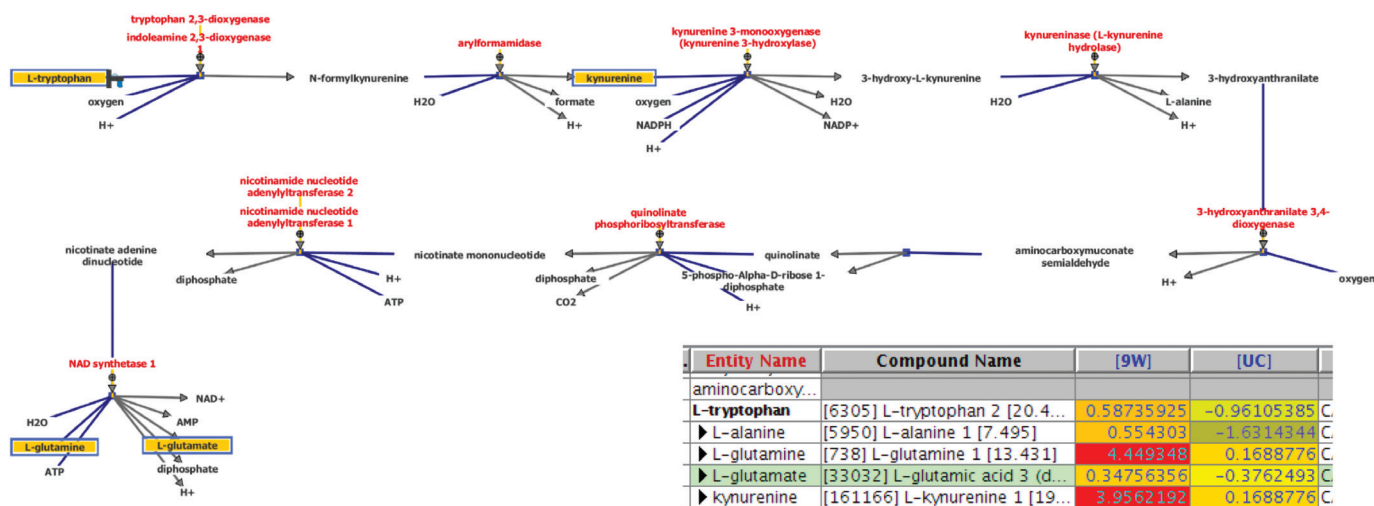

Example of Pathway Architect results: NAD biosynthesis

Streamline your metabolite identification with an accurate mass metabolomics spectral library and database

The new Agilent GC/Q-TOF metabolomics Personal Compound Database and Library (PCDL) is a high-resolution spectral library of more than 900 compounds. It represents a broad class of metabolites.

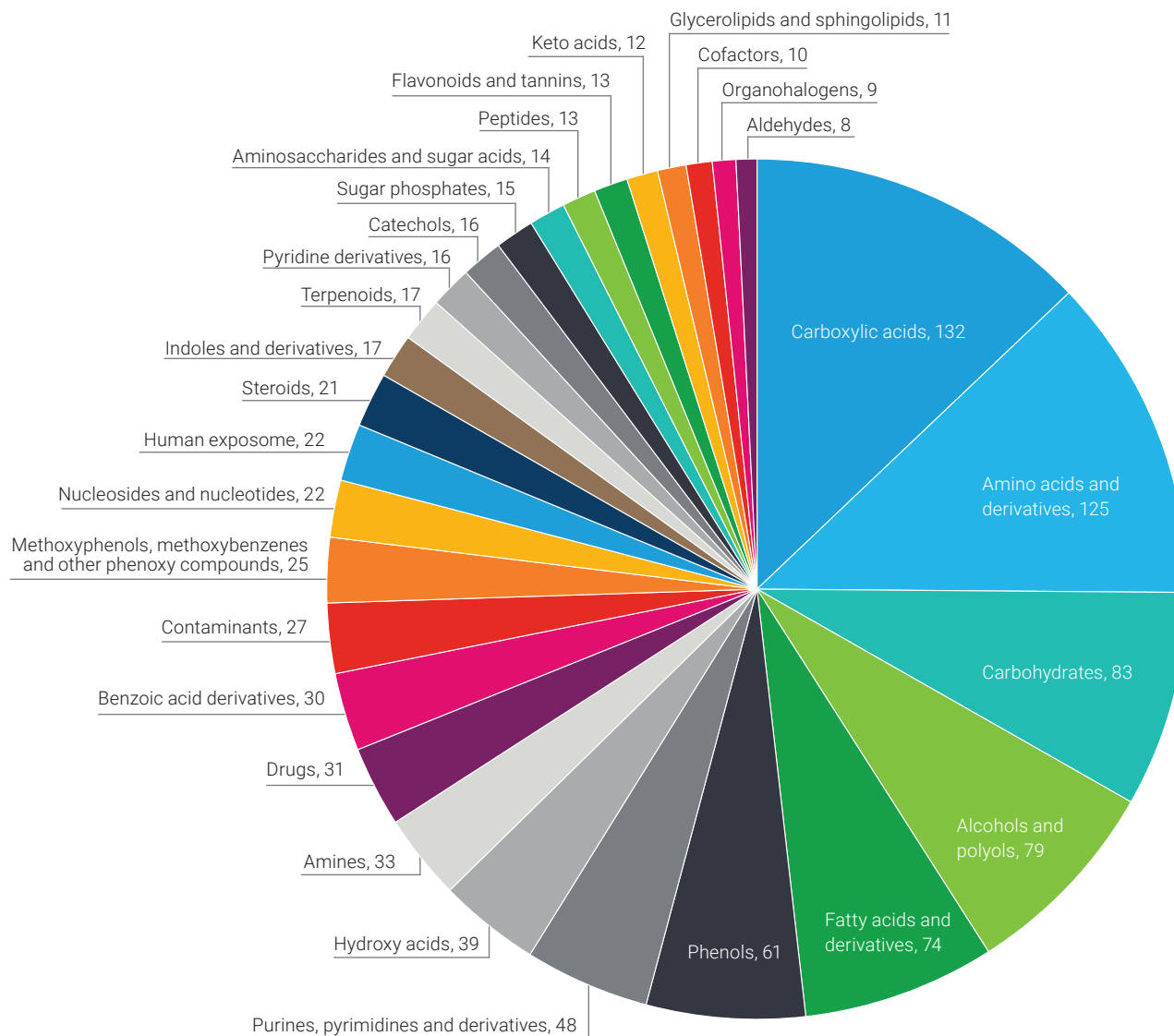

Find the Answers You Seek

Mass Profiler Professional software transforms complex data into clear insights

Differential analysis between sample groups brings focus to what is statistically significant when performing comparative studies. Here, we identified metabolite differences between healthy individuals and subjects with heart failure. The results are presented through fold change analysis on a volcano plot for easy visualization.

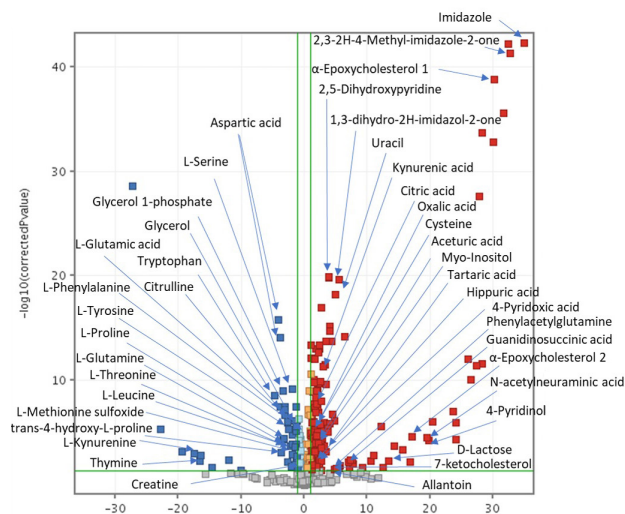

“The high-resolution Q-TOF MS, combined with the Mass Profiler software, has enabled us to study the different matrix components that coelute with the pesticides of interest.”

– Carmen Ferrer, PhD

Analytical Department, University of Almeria

Agilent ChemVista software features extensive, comprehensive integrated libraries

Agilent ChemVista is a standalone software application that manages spectral libraries created by LC/Q-TOF and GC/Q-TOF mass spectrometry. It integrates compound details, retention time, and spectral information from multiple sources, allowing you to:

- Access multiple public databases and curated libraries.
- Organize, manage, edit, or create spectra.
- Facilitate identification workflows within MassHunter data analysis applications and beyond.
- Identify compounds with greater confidence.

In addition, ChemVista includes extensive preloaded library and database content.

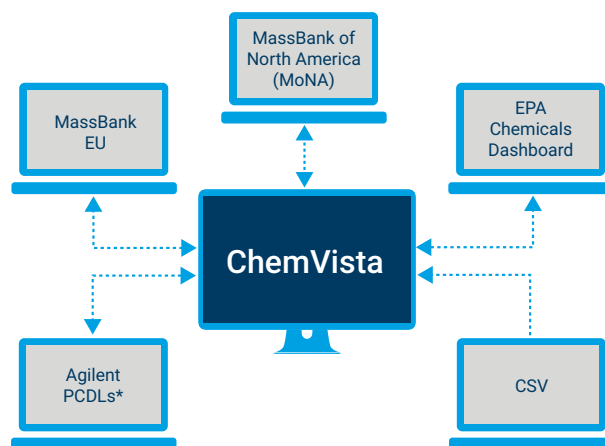

*Curated Personal Compound Databases and Libraries



CrossLab is an Agilent capability that integrates services, consumables, and lab-wide resource management to help laboratories improve efficiency, optimize operations, increase instrument uptime, develop user skill, and more. Our industry-leading services keep your instruments running at peak performance, and include technology refreshes, application consulting, repairs, preventive maintenance, compliance verification, and education.

Agilent CrossLab supports Agilent and select non-Agilent instruments and provides consultative support for workflow enablement, lab analytics, compliance, inventory management, and asset management, including relocation services.

[Learn more about Agilent CrossLab](#) and see examples of insight that leads to great outcomes.

Learn more:

www.agilent.com/chem/gcms-qtof

Find a local Agilent customer center in your country:

www.agilent.com/chem/contactus

U.S. and Canada

1-800-227-9770

agilent_inquiries@agilent.com

Europe

info_agilent@agilent.com

Asia Pacific

inquiry_lsca@agilent.com

For Research Use Only. Not for use in diagnostic procedures.

This information is subject to change without notice.

RA45442.6111111

© Agilent Technologies, Inc. 2024
Published in the USA, June 5, 2024
5991-8109EN

